



Media Technology & Solutions Pvt. Ltd.

Inventory Catalogue

Email: info@sslmediatech.com | Tel: 022-23811823 | Mob: +91- 9820022984

HYL 600 Profile Spot



The SSL Spot 600 is your all-in-one fixture for theater, TV, and live events. With crisp framing, a powerful zoom range, and captivating visual effects, it offers unmatched performance with its 600W LED engine.

Featuring an innovative framing section with 8 independent blades, creating different shapes becomes effortless, regardless of the luminaire's position. The framing system's impressive rotation of $\pm 45^\circ$ adds further flexibility, allowing you to frame any object precisely to achieve your desired artistic vision.

Additionally, the specially designed gobos, animation wheel, and prism allow you to infuse mesmerizing visual effects and dynamic elements into your productions.

Elevate your productions to new heights with the unparalleled brilliance of the SSL Spot 600.



Technical Specifications

Optics	
Lamp	600W White LED
CT	8000K/6500K
Life	20,000H
CRI	≥74 or:≥ 90 Power
Max power consumption	850W
Power supply	Electronic auto-ranging
Input voltage range	100–240V, 50-60Hz

Movement	
Pan movement	540°/630°optional (16bit)
Tilt movement	270° (16 bit)
Advanced motion system	auto repositioning, fast, quiet, and smooth

Colors	
CMY color mixing	
CTO linear	
CT1	2700K~8000K
CT2	2700K~6500K
1 Color wheel	7 dichroic filters + open

Gobos	
1 Rotating gobo wheel	6 interchangeable + open
1 Static gobo wheel	7 + open

Dimensions and weight	
Body size	290x390x740mm
Net weight	30kg



Features

Rotating prism	5-facet prism
Focus	motorized focus
Shutter	electronic, variable from 1-25Hz or random
Dimming	0-100% linear dimming
Frost	0-100% linear adjustment
Zoom	7°-42° linear zoom
Animation wheel	special dynamic flame or water effect, etc
Framing system	with 8 independent blades, rotation of $\pm 45^\circ$

Display

LCD display with battery operated for fast addressing
15 second standby auto lock
Pan/ Tilt disengage (hold MENU and ENTER button)

Software

7 built-in program (optional)
Upgrades: fast and convenient using uploaded over DMX
Remote reset DMX address, fixture reset, sound control by DMX
Run time of LED engine and fixture
2 Control channel modes: 34/54 channels

Other Specification

Input signal isolation
Optional installed wireless receiver
Optional ArtNET control
RDM compatible



Media Technology & Solutions

Email: info@sslmediatech.com

Tel: 022-23811823

Mob: +91- 9820022984

Animation Wheel

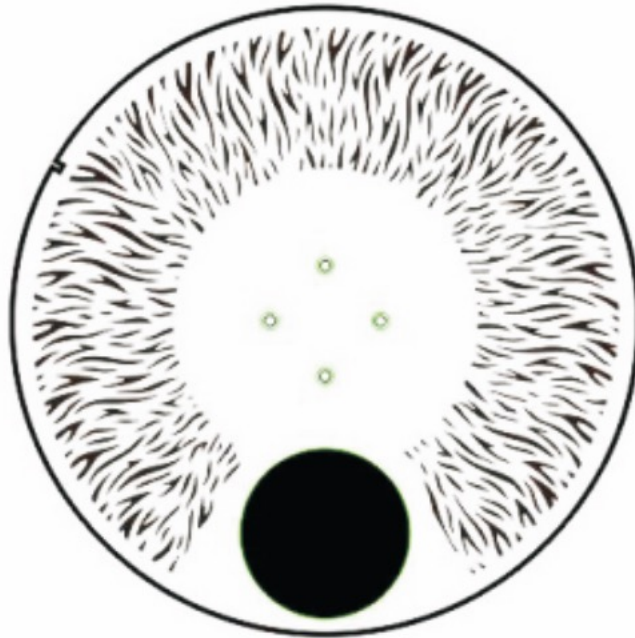

Static Gobo



Rotating Gobos





Media Technology & Solutions

Email: info@sslmediatech.com

Tel: 022-23811823

Mob: +91- 9820022984

Dimensions

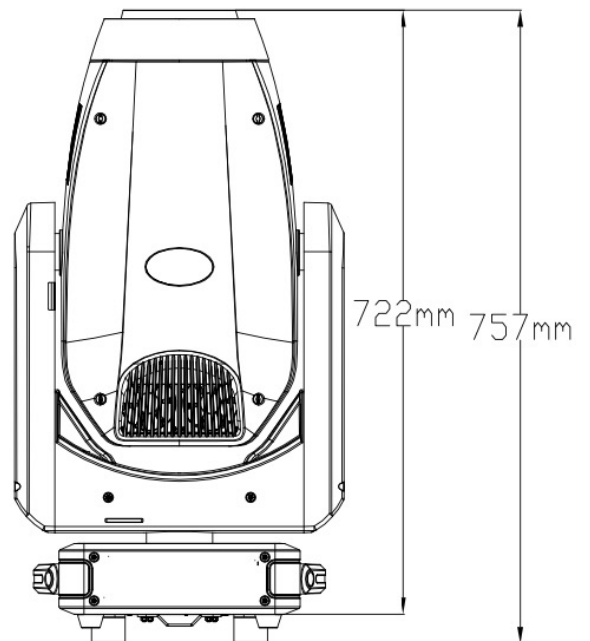
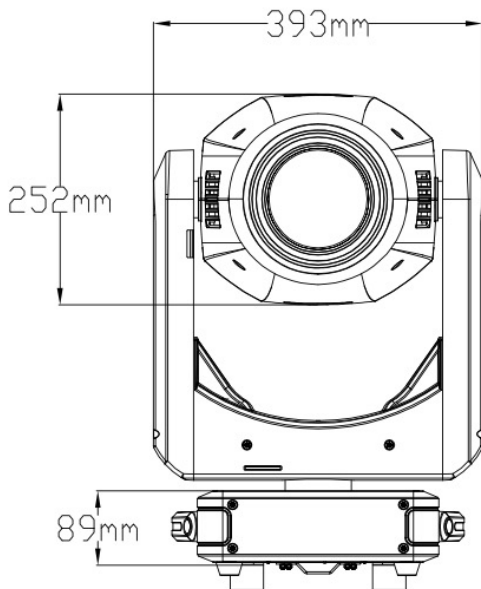
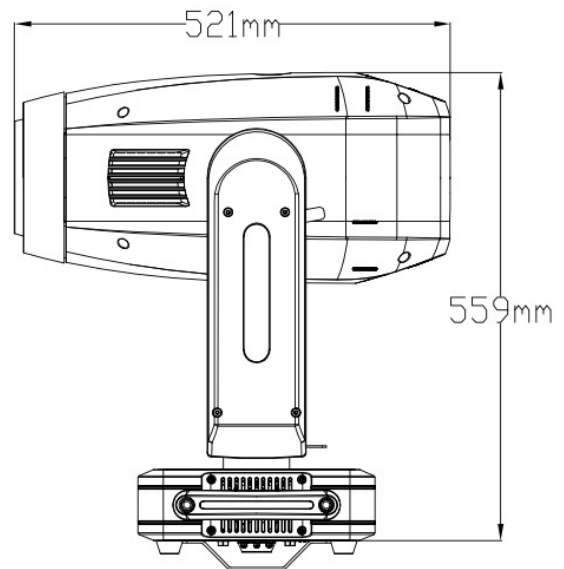
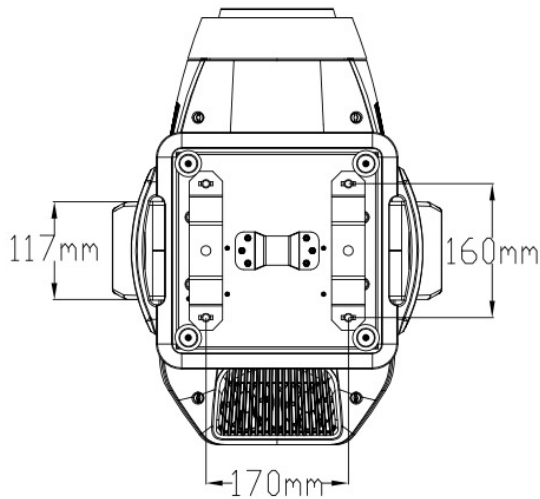

Photometrics

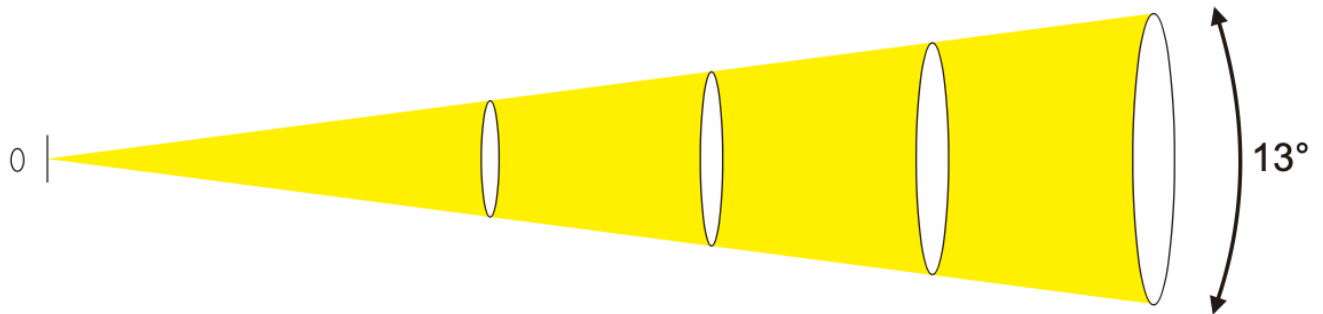

illumination	19347LM	12000LM	2747LM	2000LM
Spot Diameter	∅1.1m	∅2.3m	∅3.17m	∅4.6m
optical range	5m	10m	15m	20m

Low Ra:	5m	Ra: 74.2	spot	0.65m	23733LM
	5m		spot	1.1m	19347LM
	5m	Ra: 74.2	spot	3.17m	2747LM
Hight Ra:	5m	Ra: 96	spot	0.65m	22298LM
	5m		spot	1.1m	16026LM
	5m	Ra: 95.9	spot	3.17m	2152LM